

A4 INTRINSICALLY SAFE & NON-INCENDIVE RATED PRESSURE TRANSMITTER INSTRUCTION SHEET



⚠️ WARNING! READ ⚠️ BEFORE INSTALLATION

1. GENERAL:

A failure resulting in **injury or damage** may be caused by excessive overpressure, excessive vibration or pressure pulsation, excessive instrument temperature, corrosion of the pressure containing parts, or other misuse. Consult Ashcroft Inc., Stratford, Connecticut, USA before installing if there are any questions or concerns.

2. OVERPRESSURE:

Pressure spikes in excess of the rated overpressure capability of the transducer may cause **irreversible electrical and/or mechanical damage** to the pressure measuring and containing elements.

Fluid hammer and surges can destroy any pressure transducer and must always be avoided. A pressure snubber should be installed to eliminate the damaging hammer effects. Fluid hammer occurs when a liquid flow is suddenly stopped, as with quick closing solenoid valves. Surges occur when

flow is suddenly begun, as when a pump is turned on at full power or a valve is quickly opened.

Liquid surges are particularly damaging to pressure transducers if the pipe is originally empty. To avoid damaging surges, fluid lines should remain full (if possible), pumps should be brought up to power slowly, and valves opened slowly. To avoid damage from both fluid hammer and surges, a surge chamber should be installed.

Symptoms of fluid hammer and surge's damaging effects:

- Pressure transducer exhibits an output at zero pressure (large zero offset).
- Pressure transducer output remains constant regardless of pressure
- In severe cases, there will be no output.

FREEZING:

Prohibit freezing of media in pressure port. Unit should be drained (mount in vertical position with electrical termination upward) to prevent possible overpressure damage from frozen media.

3. STATIC ELECTRICAL CHARGES:

Any electrical device may be susceptible to damage when exposed to static electrical charges. To avoid damage to the transducer observe the following:

- Operator/installer should follow the proper ESD (electrostatic discharge) protection procedures before handling the pressure transducer.
- Ground the body of the transducer **BEFORE** making any electrical connections
- When disconnecting, remove the ground **LAST!**

Note: The shield and drain wire in the cable (if supplied) is not connected to the transducer body, and is not a suitable ground.

4. HAZARDOUS AREA SPECIFIC GUIDELINES

1. Do not open unit when energized.
2. Do not disconnect equipment unless area is known to be non-hazardous.

Ashcroft® A4 Pressure Transmitter, Typical Dimensions and Construction*

Enclosure Option "S"

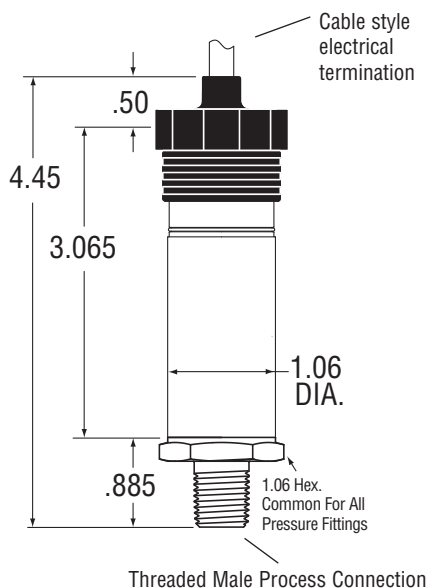

Enclosure Option "W"

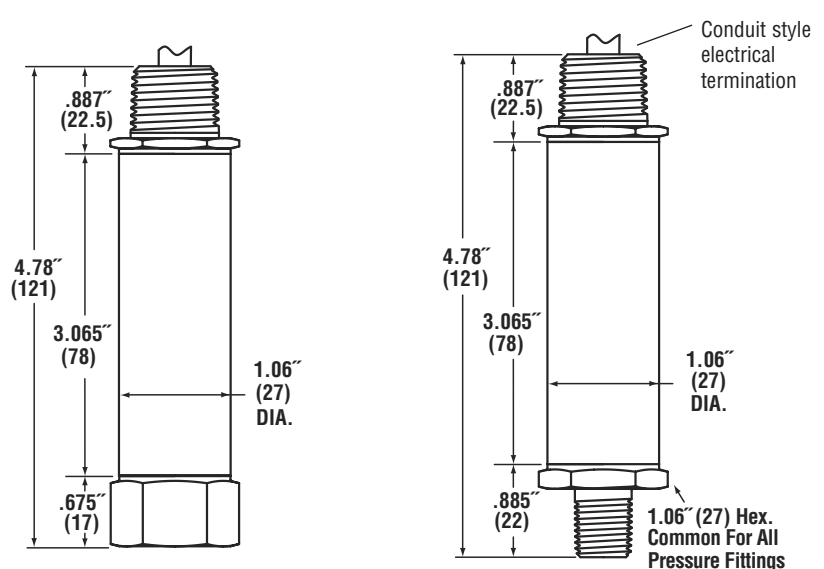

*Dimensions and construction details may vary based on product specified.

4.3 FM INSTALLATION GUIDELINES

INSTALLATION FOR FM INTRINSICALLY SAFE CLASS 1, GROUPS A, B, C & D & CLASS II, GROUPS E, F & G & CLASS III

INSTALLATION NOTES

V_{oc} OR $V_t \leq 30VDC$
 I_{sc} OR $I_t \leq 100mA$
 $C_a \geq 0.053\mu F + C_{cable}$
 $L_a \geq 0.364\mu H + L_{cable}$

1. THE INTRINSIC SAFETY ENTITY CONCEPT ALLOWS THE INTERCONNECTION OF TWO INTRINSICALLY SAFE DEVICES FM APPROVED WITH ENTITY PARAMETERS NOT SPECIFICALLY EXAMINED IN COMBINATION AS A SYSTEM WHEN: V_o OR V_{oc} OR $V_t \leq V_{max}$, I_o OR I_{sc} OR $I_t \leq I_{max}$, C_a OR $C_o \geq C_i + C_{cable}$, L_a OR $L_o \geq L_i + L_{cable}$, $P_o \leq P_i$.
2. THE NONINCENDIVE FIELD WIRING CONCEPT ALLOWS INTERCONNECTION OF NONINCENDING FIELD WIRING APPARATUS WITH ASSOCIATED NONINCENDIVE FIELD APPARATUS USING ANY OF THE WIRING METHODS PERMITTED FOR NONHAZARDOUS (UNCLASSIFIED) LOCATIONS WHEN: V_o OR V_{oc} OR $V_t \leq V_{max}$, I_o OR I_{sc} OR $I_t \leq I_{max}$, C_a OR $C_o + C_{cable}$, L_a OR $L_o \leq L_i + L_{cable}$, $P_o \leq P_i$.
3. FOR DIVISION 1 INSTALLATIONS, THE CONFIGURATION OF ASSOCIATED APPARATUS SHALL BE FM APPROVED UNDER ENTITY CONCEPT.
4. FOR DIVISION 2 INSTALLATIONS USING NONINCENDIVE FIELD WIRING CONCEPTS THE ASSOCIATED APPARATUS SHALL BE FM APPROVED UNDER THE ENTITY CONCEPT OR NONINCENDIVE FIELD WIRING CONCEPT.
5. FOR DIVISION 2 INSTALLATIONS THE ASSOCIATED APPARATUS IS NOT REQUIRED TO BE FM APPROVED UNDER ENTITY CONCEPT OR NONINCENDIVE FIELD WIRING CONCEPT IF THE A2X(4-20mA) & A4 SERIES PRESSURE TRANSDUCER IS INSTALLED IN ACCORDANCE WITH THE NATIONAL ELECTRICAL CODE (ANSI/NFPA 70) FOR DIVISION 2 WIRING METHODS EXCLUDING NONINCENDIVE FIELD WIRING.
6. CONTROL EQUIPMENT CONNECTED TO THE ASSOCIATED APPARATUS SHALL NOT USE OR GENERATE MORE THAN 250VRMS OR VDC.
7. DIVISION 1 INSTALLATIONS SHOULD BE IN ACCORDANCE WITH ANSI/ISA RP12.06.01, "INSTALLATION OF INTRINSICALLY SAFE SYSTEMS FOR HAZARDOUS (CLASSIFIED) LOCATIONS" AND THE NATIONAL ELECTRICAL CODE (ANSI/NFPA 70).
8. ASSOCIATED APPARATUS MANUFACTURERS INSTALLATION DRAWING SHALL BE FOLLOWED WHEN INSTALLING THIS EQUIPMENT.
9. RUN SHIELDED INTERCONNECTION CABLE WITH SHIELD CONNECTED TO FM APPROVED ASSOCIATED APPARATUS GROUND.
10. WARNING – DO NOT OPEN WHEN ENERGIZED.
11. WARNING – DO NOT DISCONNECT EQUIPMENT UNLESS AREA IS KNOWN TO BE NON-HAZARDOUS.

HAZARDOUS (CLASSIFIED) AREA

CLASS I, DIVISION 1 & 2,
 GROUPS A, B, C, & D;
 CLASS II, DIVISION 1 & 2,
 GROUPS E, F & G, CLASS III

NON-HAZARDOUS (UNCLASSIFIED) AREA

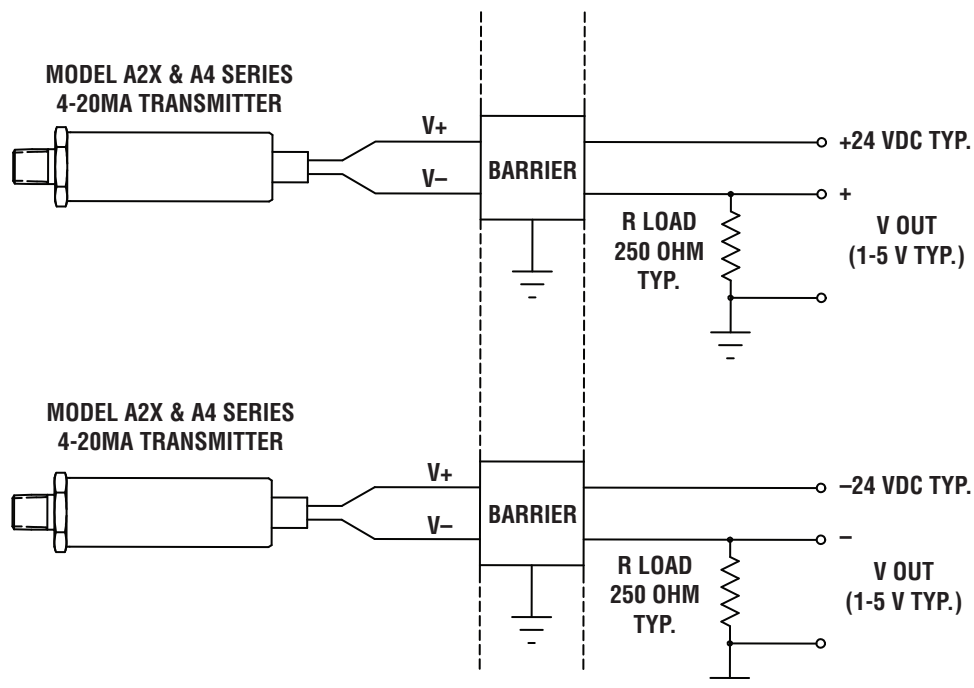

4.4 CSA INSTALLATION GUIDELINES

INSTALLATION FOR CSA INTRINSICALLY SAFE CLASS 1, GROUPS A, B, C & D & CLASS II, GROUPS E, F & G & CLASS III

INSTALLATION NOTES:

V_{max} 30VDC
 I_{max} 100mA
 $C_i = 0.053\mu F$
 $L_i = 0.364\mu H$

1. THE INTRINSIC SAFETY ENTITY CONCEPT ALLOWS THE INTERCONNECTION OF TWO INTRINSICALLY SAFE DEVICES CSA CERTIFIED WITH ENTITY PARAMETERS NOT SPECIFICALLY EXAMINED IN COMBINATION AS A SYSTEM WHEN: U_o OR V_{oc} V_{max} , I_o OR I_{sc} I_{max} , C_a OR C_o $C_i + C_{cable}$, L_a OR L_o $L_i + L_{cable}$, P_o P_i .
2. THE NONINCENDIVE FIELD WIRING CONCEPT ALLOWS INTERCONNECTION OF NONINCENDING FIELD WIRING APPARATUS WITH ASSOCIATED NONINCENDIVE FIELD APPARATUS USING ANY OF THE WIRING METHODS PERMITTED FOR NON3HAZARDOUS (UNCLASSIFIED) LOCATIONS WHEN:
 U_o OR V_{oc} V_{max} , I_o OR I_{sc} I_{max} ,
 C_a OR $C_o + C_{cable}$, L_a OR L_o $L_i + L_{cable}$, P_o P_i .
3. FOR DIVISION 1 INSTALLATIONS, THE CONFIGURATION OF ASSOCIATED APPARATUS SHALL BE CSA CERTIFIED UNDER ENTITY CONCEPT.
4. FOR DIVISION 2 INSTALLATIONS USING NONINCENDIVE FIELD WIRING CONCEPTS THE ASSOCIATED APPARATUS SHALL BE

CSA CERTIFIED UNDER THE ENTITY CONCEPT OR NONINCENDIVE FIELD WIRING CONCEPT.

5. FOR DIVISION 2 INSTALLATIONS THE ASSOCIATED APPARATUS IS NOT REQUIRED TO BE CSA CERTIFIED UNDER ENTITY CONCEPT OR NONINCENDIVE FIELD WIRING CONCEPT IF THEA2X (4-20mA) & A4 SERIES PRESSURE TRANSDUCER IS INSTALLED IN ACCORDANCE WITH THE CANADIAN ELECTRICAL CODE (CEC, CAN/CSA3C22.1) FOR DIVISION 2 WIRING METHODS EXCLUDING NONINCENDIVE FIELD WIRING.
6. CONTROL EQUIPMENT CONNECTED TO THE ASSOCIATED APPARATUS SHALL NOT USE OR GENERATE MORE THAN 250VRMS OR VDC.
7. ASSOCIATED APPARATUS MANUFACTURERS INSTALLATION DRAWING SHALL BE FOLLOWED WHEN INSTALLING THIS EQUIPMENT.
8. RUN SHIELDED INTERCONNECTION CABLE WITH SHIELD CONNECTED TO FM APPROVED ASSOCIATED APPARATUS GROUND.
9. WARNING – SUBSTITUTION OF COMPONENTS MAY IMPAIR INTRINSIC SAFETY
10. WARNING – TO PREVENT IGNITION OF FLAMMABLE OR COMBUSTIBLE ATMOSPHERES, DISCONNECT POWER BEFORE SERVICING.

HAZARDOUS (CLASSIFIED) AREA

CLASS I, DIVISION 1 & 2,
 GROUPS A, B, C, & D;
 CLASS II, DIVISION 1 & 2,
 GROUPS E, F & G, CLASS III

NON-HAZARDOUS (UNCLASSIFIED) AREA

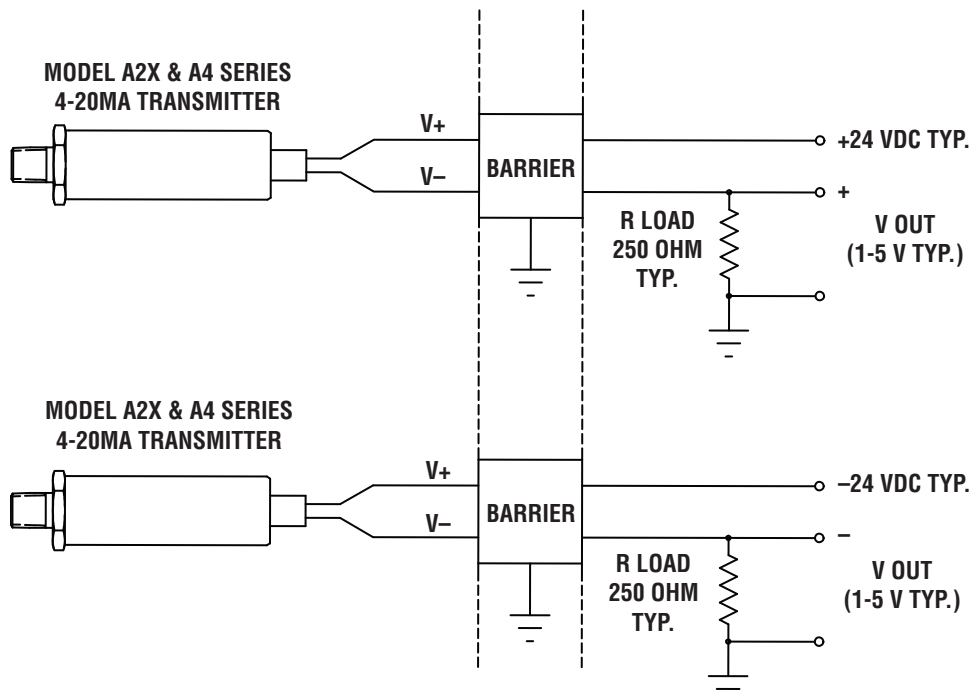

A4 INTRINSICALLY SAFE & NON-INCENDIVE RATED PRESSURE TRANSMITTER INSTRUCTION SHEET



Mounting

The A4 transmitter requires no special mounting hardware, and can be mounted in any plane with negligible position error.

Although the unit can withstand normal vibration without damage or significant output effects, it is always good practice to mount the transducer where there is minimum vibration.

For units with NPT type pressure fittings apply Teflon® tape or an equivalent sealant to the threads before installing.

When tightening, apply a wrench to the hex wrench flats located just above the pressure fitting. **DO NOT** tighten by using a pipe wrench on the housing.

Power Supply

Output Signal	Power Supply Voltage	
	Min	Max
4-20mA*	12V**	30V

* Refer to Ashcroft drawing #825A022 for supply voltage and load limit.

** The minimum voltage at the terminals is 12Vdc. However, the minimum supply voltage should be calculated using the following graph and formula.

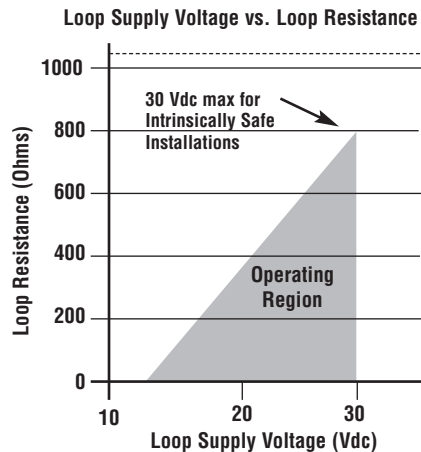

$$V_{min} = 12V + (.022A \times RL) \text{ (includes a 10\% safety factor)}$$

$$RL = RS + RW$$

RL = Loop Resistance (ohms)
RS = Sense Resistance (ohms)
RW = Wire Resistance (ohms)

Noise

For minimum noise susceptibility, avoid running the transducer's cable in a conduit that contains high current AC power cables. Where possible avoid running the cable near inductive equipment.

Shielded Cable

Units with shielded cable electrical termination, connect the drain wire to the guard terminal on the read out device or measuring instrument, if available. In all other cases connect to the ground or to the power supply negative terminal.

Vent Tube (Cable Termination Only)

The cable has a clear Teflon® vent tube required at pressure ranges below 500 psi to provide atmospheric reference. The open end should be placed in a dry area.

A4 Wiring Diagrams

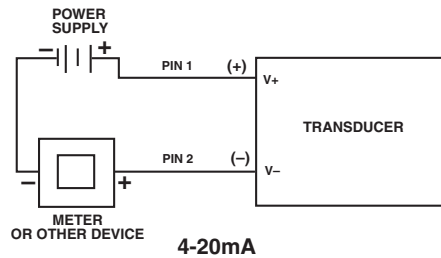

A4 transducer has internal transient protection: for safety, limit line-to-ground voltage to 36 Vdc max.

Zero and Span Adjustment

Instructions below apply to the particular configurations noted. While Zero adjustment is not normally necessary, it may be desirable to trim out any offset in the system. However, proper Span calibration requires a pressure standard three to five times more accurate than the accuracy of the transducer, and there may also be interaction of Span on Zero.

A4 configurations with enclosure "S" offer Zero and Span potentiometer access.

Access to "Z" and "S" pots via the top (electrical termination end) of the unit is standard on all "S" enclosure units with 4-20mA output. Access is gained by removing the black threaded cap, once removed you will see the pots indicated by "Z" and "S" respectively as shown below. Using a small trim pot tool, you can adjust zero $\pm 10\%$ of full scale and span $\pm 10\%$ of full scale.

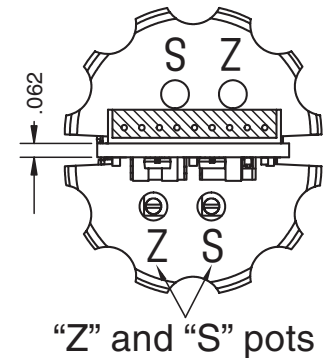

Recalibration Instructions:

1. Apply 0% full scale pressure.
2. Adjust the output using the zero adjust trim pot.
3. Apply 100% full scale pressure.
4. Adjust the output using the span adjustment trim pot.
5. Repeat steps 1 through 4 as necessary.

HAZARDOUS AREA CERTIFICATIONS

Intrinsically Safe (applies to 4-20mA) FM/CSA:

Intrinsic Safety: Class I, II and III Div.1 and 2, Groups A, B, C, D, F and G per entity requirements see Ashcroft drawing # 825A022

Non-Incendive: Class I, II and III Div.1 and 2, Groups A, B, C, D, F and G, no barriers needed

A4 INTRINSICALLY SAFE & NON-INCENDIVE RATED PRESSURE TRANSMITTER INSTRUCTION SHEET



Pin #	Voltage Output	Current Output
A	(+) Power	(+) Power
B	(+) Output	None
C	Field Gnd.	Field Gnd.
D	(-) Power	(-) Power

Wire Color	Voltage Output	Current Output
Red	(+) Power	(+) Power
White	(+) Output	None
Black	(-) Power	(-) Power
Green	Field Gnd.	Field Gnd.
Bare	Drain Wire	Drain Wire

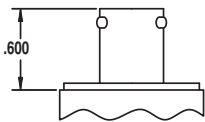
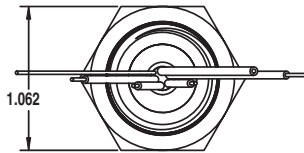
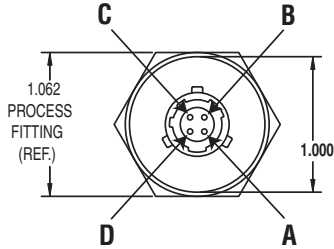

(4) PIN BENDIX STYLE
ELECTRICAL TERMINATION
SHELL SIZE 8
(B4), (H1), (L1), (P2)

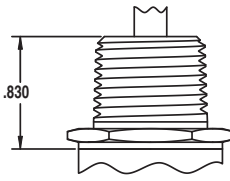

PIGTAIL
ELECTRICAL TERMINATION
CONDUIT - 1/2 NPT MALE
(C1), (P7)

ELECTRICAL TERMINATIONS FOR WELDED HOUSINGS ONLY

Pin No.	Voltage Output	Current Output	Mating Cable Color
1	(+) Power	(+) Power	Red
2	(+) Output	None	White
3	Field Gnd.	Field Gnd.	Green
4	(-) Power	(-) Power	Black

Pin No.	Voltage Output	Current Output	Mating Cable Color
1	(+) Power	(+) Power	Red
2	(-) Power	(-) Power	Black
3	(+) Output	None	White
GND	Field Gnd.	Field Gnd.	Green

Pin No.	Voltage Output	Current Output	Mating Cable Color
A	(+) Power	(+) Power	Red
B	(+) Output	None	White
C	Field Gnd.	Field Gnd.	Green
D	(-) Power	(-) Power	Black

Wire Color	Voltage Output	Current Output
Red	(+) Power	(+) Power
White	(+) Output	None
Black	(-) Power	(-) Power
Green	Field Gnd.	Field Gnd.
Bare	Drain Wire	Drain Wire

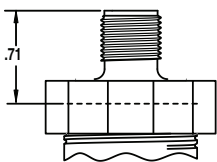
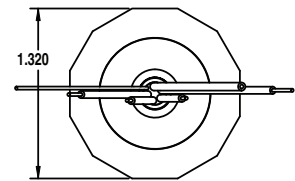
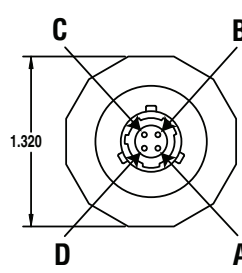
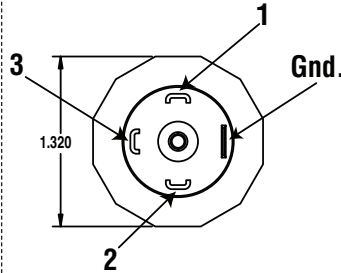
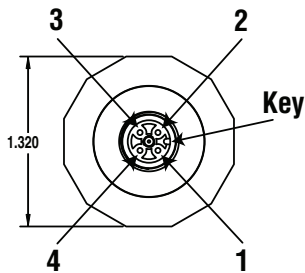

M12
ELECTRICAL TERMINATION
(EW), (E0), (E1), (E2)

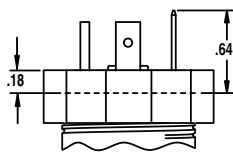

DIN 43650-A
ELECTRICAL TERMINATION
(CD), (DN), (D0), (D1), (D2)

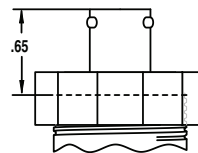

(4) PIN BENDIX STYLE
ELECTRICAL TERMINATION
SHELL SIZE 8
(B4), (H1), (L1), (P2)

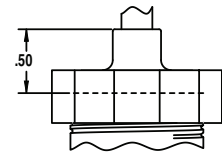

PIGTAIL
ELECTRICAL TERMINATION
PLASTIC MOLDED
(F2), (P1)

Willy Instrumentos de Medição e Controle Ltda.
(An Ashcroft® Inc. Company)
Rua João Pessoa, 620 - São Caetano do Sul -
São Paulo - Brazil - 09520-000
Tel.: (55 11) 4224-7400 • Fax: (55 11) 4224-7477
vendas@ashcroft.com • www.ashcroft.com.br